

DEPARTMENT OF
UNIVERSITY OF

ESSAY
"Hydropneumatic car suspension"

STUDENT:

PROGRAM TUTOR:

ACADEMIC YEAR: 200.../0...

DATE:

UNIT No:

SUMMARY

The main topic of this report is the use of hydropneumatic suspension by automotive industries, and how it came to evolve in every new generation of automobiles, from the very first time it was used until this day.

An introduction is made to the main principles of this suspension type and how the combination of fluid, gas and several accumulators in a suspension can provide both a good level of comfort and good handling. Firstly the main circuit is examined with its components, and then without much detail the improvements are shown. The rest of the report presents the improvements the designers made to hydropneumatic suspension systems over the years, and how several companies have tried to utilize this kind of suspension in their cars. .

1. INTRODUCTION

The main objective of hydropneumatic suspension is to eliminate the body roll of a car when cornering at a high speed. Additionally, the hydraulic system can enable self-levelling, variable ride height, assisted jacking. Furthermore, it can provide the hydraulic power to assist the braking systems and the power steering. In some car models, the high pressure hydraulic system also operated the clutch and gear change.

Generally speaking, the idea of using a hydraulic circuit as a suspension instead of springs and dampers is quite effective, and has been in use for half a century. The first automotive company to use this kind of suspension was Citroen.

2. MAIN COMPONENTS

The basis of the hydraulic system is the reservoir that contains the hydraulic oil. It must be big enough not only to contain the fluid necessary for normal operation, but also all the hydraulic fluid required to bring the suspension up to full height. Other main components are:

2.1 High-Pressure Pump

The Citroën system relies on an engine-driven pump to pressurise the hydraulic system. A simple piston, as shown in Fig.1, is at the heart of the pump. When the piston ascends, a valve opens to allow fluid to be drawn from the reservoir. When the piston descends, the valve closes and another opens, allowing fluid to be forced out under pressure. This is able to generate enough hydraulic pressure to hold the car body up even under stress and heavy loads. In order to generate an uninterrupted flow of pressurized fluid, the pump unit actually consists of seven pistons arranged in a circle. By rotating an armature, each piston is depressed in succession and a constant supply of fluid is produced. [3]

2.2 Pressurized Spheres

A primary component of the Citroën hydraulic system is the pressurized sphere. There are as many as six such units in some models. Although each one functions in exactly the same way, they are used for a variety of purposes.

Each unit is composed of two halves. When screwed together they form a solid unit that has a perfectly spherical cavity inside. Note: more modern sphere units do not unscrew into halves, but are manufactured as integrated units. A curved rubber bladder conforms to one

half of the cavity, secured in the layer between the two halves. The cavity is then completely charged with compressed nitrogen, creating a very stable pressurized environment.

Hydraulic fluid can enter the unit through an orifice below the bladder. The nitrogen gas is further compressed upwards by the rubber bladder, as a quantity of fluid is pushed into the cavity. When pressure outside the unit decreases, the fluid is forced back out of the cavity, and the compressed nitrogen attains equilibrium again. [3]

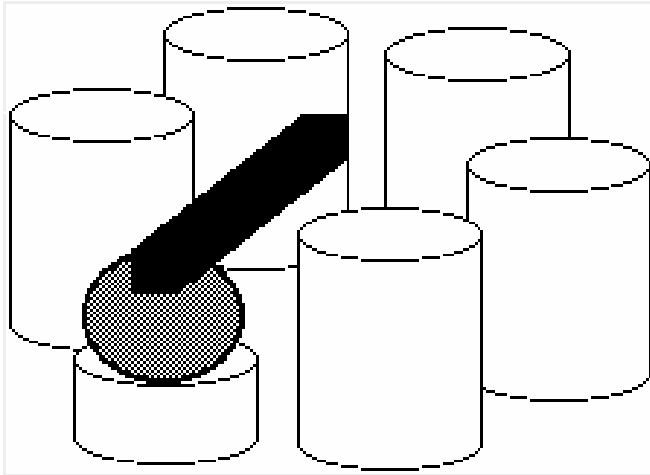

Figure 1: The schematic of a high-pressure pump [3]

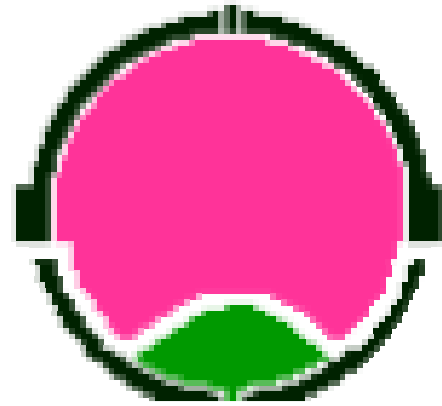

Figure 2: The schematic of a pressurized sphere [3]



Figure 3: An actual picture of a pressurized sphere in a car [3]

2.3. The Main Accumulator

One of the main uses of the pressurized sphere is to be the main accumulator that collects high-pressure fluid from the pump and distributes it to the subsystems. It is fed directly from the main pump through a pressure regulator valve. When pressure is low, e.g. at start-up time, pressurized fluid from the pump is sent into the accumulator and when the accumulator achieves adequate pressure, the switch acting as a relief valve diverts fluid from the pump directly back to the reservoir.

Each of the subsystems draws more or less directly from this sphere as pressure is needed to perform a specific function. If the subsystems drew fluid from the pump they would get variable spurts. So the accumulator acts like a buffer, providing a constant flow of pressurized fluid. [3]

2.4. The "Load-bearing" Shock Absorbers

Each load-bearing shock absorber is a simple cylinder/piston with a pressurized sphere on top of it, Figure 4. Hydraulic fluid can pass back and forth between the piston and the sphere. The pressure of the compressed nitrogen in the sphere counteracts the force of the weight of the body. An orifice between the piston and the sphere produces a dampening effect. In this way the compressed nitrogen acts like a damper whereas the high pressure fluid performs just like springs or torsion bars would in conventional cars. [3]

2.5. The Height Control Valves

The height control valves are operated by a mechanical arm that extends from the device. When the arm is pushed into the valve, a path is created between the high-pressure feed and the suspension elements. When the arm is pulled out from the valve, a path is created between the suspension elements and the reservoir. When the arm is in the neutral position, no fluid can flow in either direction.

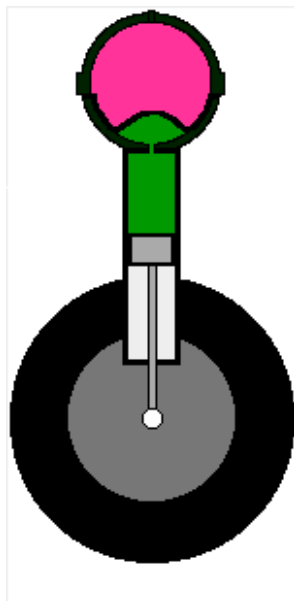

Figure 4: The "Load-bearing" shock absorber attached on a wheel [3]

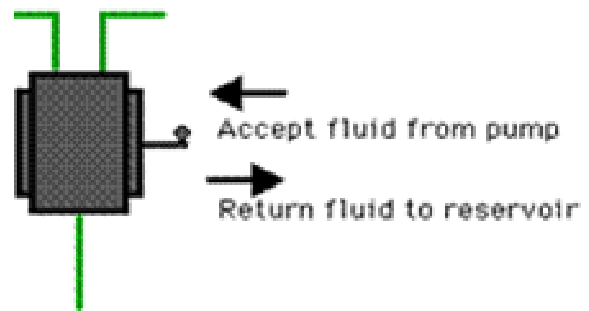

Figure 5: Height control valve [3]

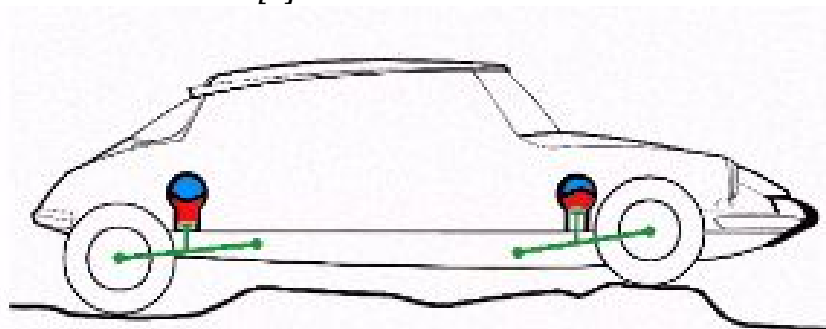

Figure 6: The suspension system in the Citroën DS [4]

Self-levelling effect is achieved by mounting the valve on the car frame and connecting the arm to the suspension, Figure 6. If a heavy load is placed in the rear end of the car, the weight will push the rear suspension downwards. That will result in the suspension forcing the valve arm inwards, letting more high-pressure fluid enter the rear suspension system until the valve arm returns to the proper position. The height adjustment lever under the dashboard adjusts the relationship between the valve arm and the suspension, thus effecting the height adjustment. [3]

2.6. The Suspension Subsystem

The suspension subsystem is fed directly from the main accumulator. The fluid feed immediately splits front and rear, each passing through a Height Control Valve. When each valve is activated, high-pressure fluid inflates the pair of load-bearing shocks. When the valve is in the neutral position, the pressure level remains constant between the pair. When the valve is deactivated, the fluid in the shock pair drains directly back to the reservoir.

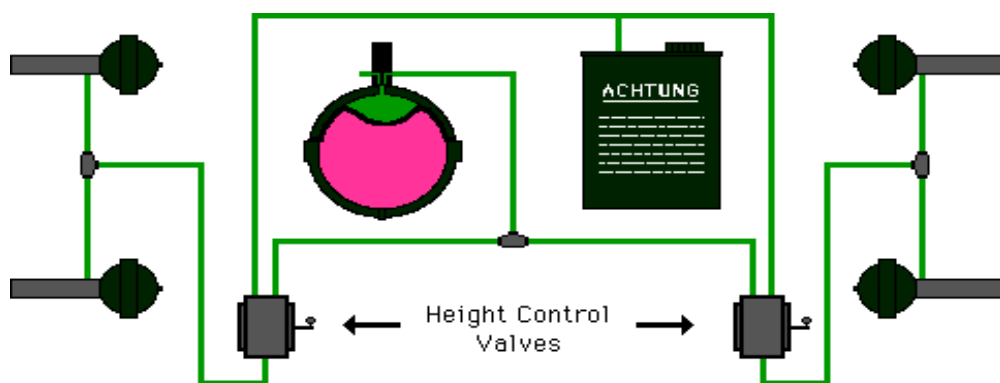

Figure 7: The schematic of the Suspension subsystem

Sharing the pressure between left and right shock absorbers proved to have many benefits. The tendency to equalize pressure between them accomplished a horizontal self-levelling, even at high speeds. This achieved a natural anti-roll effect and gave the car good cornering capabilities.

But it proved more advantageous to have pressure separated fore and aft. This was accomplished through the independent height control valves on the front and rear axis. "If the load on the rear of the car increased, the rear valve would be activated and a greater volume of high-pressure fluid would be allowed into that pair." [3]

2.7. The Brake Subsystem

The high pressure line of the suspension is connected with the brake system. Following the front/rear split of the suspension, the braking system is split into two subsystems – front and rear. Pressure in each line activates the front and rear brake callipers independently. [3]

The main reason for sharing the pressure with the suspension is safety. In the event of a complete pressure loss in the vehicle, there would be adequate pressure in the suspension to power the brakes enough to bring the car to a stop. The side effect of this, however, is that the pressure drop used for the brakes will cause a slight but sudden loss of height in the load bearing shock absorbers. Therefore another pressurized sphere is added in the system. This 'brake accumulator' stores enough pressurised fluid that the front suspension height is not affected when the brakes are applied. There is no need for such accumulator in the rear, as the loss of suspension height is counteracted by the tendency of the vehicle to 'nose dive' when braking sharply. [3]

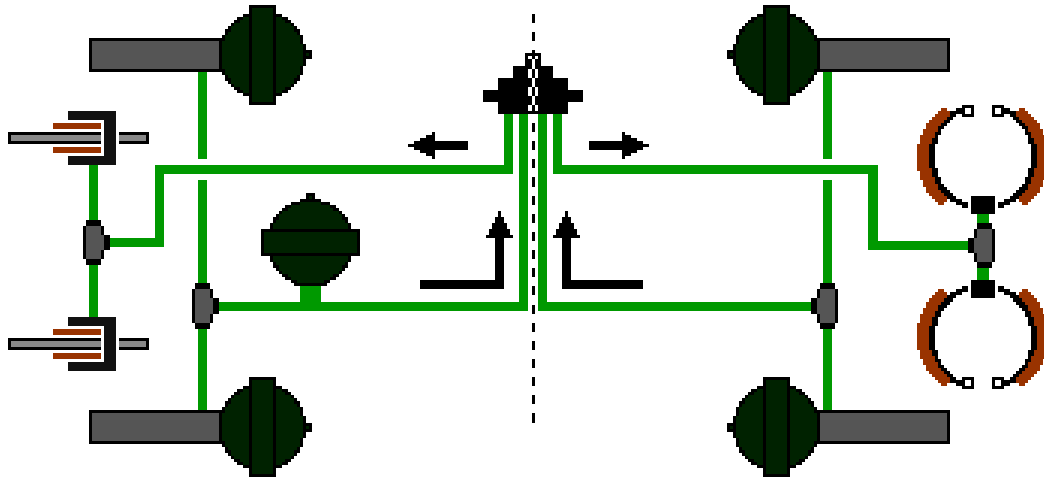

Figure 8: The schematic of the brake subsystem

3. CITROEN MODELS USING HYDROPNEUMATIC SUSPENSION

3.1. Beginnings

Hydropneumatic suspension was first shown in 1952 when it was fitted to the rear of the "15CV H Traction Avant". This was a foretaste of the system that was fitted to the revolutionary DS19 of 1955, Figure 6. Subsequently, hydropneumatic suspensions have been fitted to the GS and the SM models of 1970, the CX in the Seventies, the BX in the Eighties, as well as the XM and the Xantia in the Nineties.

3.2. Changes made over the years

The main components were used in the early DS19 of 1955. But some reliability issues came up: there were problems with seals and the fluid originally used was intensely hydroscopic (it absorbed water) which caused oxidation [4].

The introduction of LHS fluids improved matters but it was not until a mineral oil (Liquide Hydraulique Minéral) was introduced in the mid sixties that the system became thoroughly reliable. As with the conventional Citroen hydraulic suspension system, there is also a centre-mounted lever to raise or lower the suspension according to road conditions.

The introduction of the XM brought electronic control of the suspension system called Hydractive and a refined version of this system was fitted to high specification Xantia and to later XMs. Electronics provided a cheap, low weight solution for active suspension and anti lock brakes. The Hydractive system allowed for variable damping and automatic switching between soft and firm modes which allowed both ride comfort and good handling.

Also an extra sphere was added on the rear axis to provide better self-levelling and larger suspension travel.

3.3. Active Roll Control

Based on the Hydractive, one model was equipped with active roll control which incorporated a gas-filled sphere in the middle of the anti-roll bar. The sphere acts as a cushion, thus allows the anti-roll bar to be twisted more easily. Therefore, the 28 mm anti-roll bar actually performs like a slimmer (23 mm) one, thus offer less anti-roll function for normal drive.

When the car goes into a corner quickly, computer detects body roll and closes the valves in the sphere. This isolates the gas in the sphere and eliminates the cushion effect. The anti-roll bar thus resumes its original stiffness, acting exactly as a 28 mm anti-roll bar.

Hydractive II

The extra components used in the next generation of Hydractive were:

- Computer
- Steering wheel movement and speed of movement sensor
- Accelerator sensor - reads accelerator movement and rate of movement
- Additional dumpers
- Electromagnetic valve

This system switches from "soft" to "firm" modes according to a number of parameters programmed into the on board computer. The sensors provide the necessary input to the computer to determine which mode is appropriate. A central sphere on each axle is switched in and out of circuit to alter the amount of suspension travel and damping.

Steering-wheel angle, angular velocity, accelerator pedal movement, pressure in the brake circuit and the amplitude and frequency of body movements are all number-crunched within 50 milliseconds of sudden movement being detected, some three times quicker than any physical movement of the vehicle body. When driving in a more 'sporty' way the system switches to a 'firm' setting that bypasses the central sphere. Drivers who prefer a harder, more 'sporting' ride can select the firm setting manually from a switch on the panel on board.

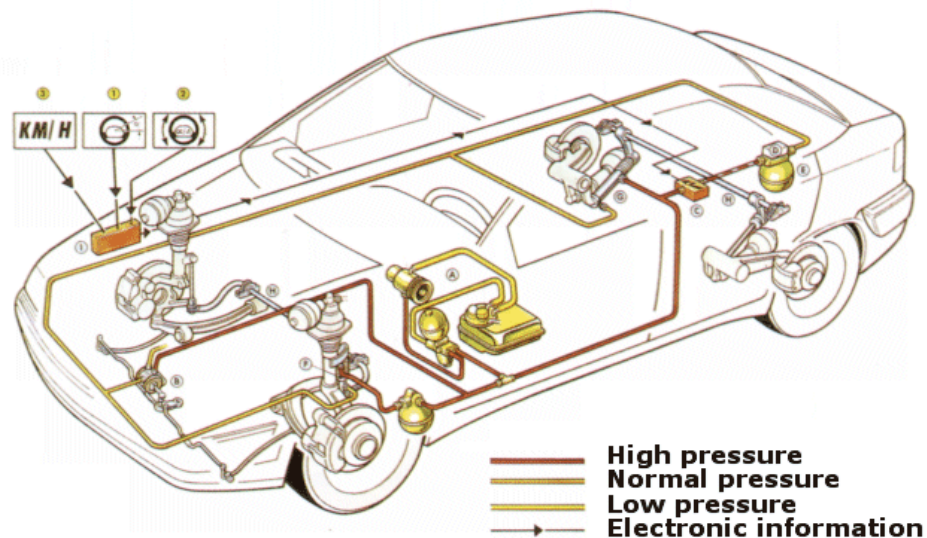

Figure 9: The schematic of the hydraulic circuit used in "Hydractive II" [4]

Hydractive III

The improvements in the following generation were mainly concentrated on the electronic adjustments. The latest version of Hydractive suspension has a so called "Built-in Hydraulic Interface". This means that it has automatic height adjustment and does that while taking consideration of a number of different conditions, including vehicle speed and road surface.

If the roads are fairly level, the car is maintained at a normal ride height up to around 65mph. Any faster, provided the road is still good, and the ride height is lowered (by 15 mm at the front and 11 mm at the rear) so that the car is aerodynamically more stable and fuel efficient. But if the BHI senses that the roads are bumpy, by the kind of movement the

suspension is making, it raises the car's height, increasing clearance without compromising handling or comfort (vehicle height can increase by 13 mm).

If the driver is engaged in 'sporty' driving, the system also senses this and firms up the suspension as required. This setting can also be selected manually with a switch, though comfort is still maintained during more restrained driving periods.

Of course, the latest Hydractive 3 system also keeps the car constantly level, regardless of load.

Another advantage is that it will not need any service for twice the period of any other conventional kind of suspension (200,000 km). [1]

4. OTHER AUTOMOTIVE COMPANIES USING ADAPTIVE SUSPENSION

Ferrari and Maserati have used adaptive suspension over the years. Though the mechanism is much simpler; by varying the total area of valves area within the shock absorber, different rate of damping can be obtained. Therefore the shock absorber alone is able to apply 'adaptive damping'. Sensors were employed to measure the longitudinal acceleration, lateral acceleration, speed, brake pressure, load and steering angle. Via analysing these data, the computer knew the driver's intention - to go fast or to travel leisurely. Then decide the most suitable damper setting. [2]

Mercedes' Active Body Control (ABC) seems quite simple in comparison with Citroen's suspension system. Each car wheel is on a hydraulic servomechanism which includes a strut, spring, damper, and a fluid chamber on top. When the chamber is filled with fluid from hydraulic pump, the spring is pushed towards the wheel and compressed, resisting the body roll. When the fluid chamber is emptied, the spring is released towards the top of the strut, becoming softer [2]. The system uses 13 different on-board sensors, which feed into the four servo mechanisms. The ABC computer adjusts the ride every 10 milliseconds, but the maximum system frequency is around 5 Hz, since the fluid filling takes time. However, that is fast enough for minimising the body roll. [5]

Lotus' fully active suspension originally intended to equip its Formula One racing cars and expressed fully optimistic that the system would go into mass production but this did not come true, due to cost, power consumption and reliability. [2]

Cadillac's continuously variable road-sensing suspension (CVRSS) has been offered from early Nineties on large sedan models - Eldorado, DeVille, and Seville STS [5]. The system uses numerous sensors to actively actuate all four hydraulic shock absorbers, improving road feel and dampening. It is essentially an adaptive but not fully active suspension.



Figure 10: New Mercedes CL model using ABC versus older model without ABC [2]

More recently, Land Rover introduced active cornering enhancement (ACE) from 1999 in the Land Rover Discovery Series II. It is the first such system for sport-utility vehicles. The ACE system replaces the standard anti-roll bars with roll control modules, which are rigid apart from the hydraulic actuator which connects the two ends of the bar. Accelerometers

monitor the lateral acceleration of the vehicle (how hard it is cornering) and the system applies an appropriate hydraulic pressure to the actuators. This pressure produces a force to counter the torque produced by the lateral acceleration of the vehicle when cornering, with capability to up to 1.0 g lateral acceleration in 250 milliseconds.

5. CONCLUSIONS

Hydropneumatic suspension was ahead of its time when it was first captured as an idea. The main principles are even used to this very day, but with a lot of assistance from the electronic sensors which simply brought to perfection something that was simply "very good". Although it was used to bring to life a fully active suspension with the control of gas and fluid within a sphere (Hydractive), it never achieved the best level of comfort while keeping the body stable. But it is easily understood that the first steps to achieving this goal were made by the Citroen and the use of compressed gas and high pressure fluid instead of coils and dampers.

From personal experience, I must say that the difference in the comfort of Hydropneumatic suspension is obvious from the very beginning. But the high maintenance cost of the first type on Hydractive, along with some problems in the height control valves, gave the impression that the technology was far from perfect.

REFERENCES

1. **Julian Marsh** "Citroën Hydropneumatic suspension" (online), accessed 24th October 2006
<http://www.citroen.mb.ca/citroenet/miscellaneous/miscellaneous-index.html>
<http://www.citroen.mb.ca/citroenet/miscellaneous/hydraulics/hydraulics-1.html>
2. **Mark Wan** 1998-2001 "Adaptive suspension" (online).accessed 25th October 2005
http://www.autozine.org/technical_school/suspension/tech_suspension3.htm
3. **Christopher Westfall** "The Citroën Hydraulic System", accessed 26th October 2006.
<http://www.actwin.com/toaph/citroen/work/work.html>
4. **Bruce Kennet and Julian Marsh**, "Citroen Hydraulic Systems", accessed 26th October 2006
<http://www.citroenet.org.uk/miscellaneous/suspension/suspension8.html>,
<http://www.citroenet.org.uk/miscellaneous/hydraulics/hydraulics-1.html>
5. **Scott Memmer**, "Suspension III: Active Suspension Systems", accessed 26th October 2006
<http://www.edmunds.com/ownership/techcenter/articles/43853/article.html>